



2 μm Polarization Maintaining Fiber Optic Circulator (PMCIR Series)

Rev 11C

The 2 μm Fiber Optic Circulator is a high performance lightwave component that routes incoming signals from Port 1 to Port 2, and incoming Port 2 signals to Port 3.

Specifications

Parameter	Unit	Value
Operating Wavelength	nm	1950 or 2000
Max. Insertion Loss, 23 °C, λc ± 30 nm	dB	1.5
Min. Isolation, 23 °C, λc ± 30 nm	dB	16
Min. Crosstalk	dB	40
Min. Return Loss	dB	50
Min. Extinction Ratio	dB	18
Max. Average Optical Power	W	0.3, 0.5, 1, 2 or 5
Max. Peak Power for ns Pulse	kW	10
Max. Tensile Load	N	5
Fiber Type		optional
Operating Temperature	°C	- 5 to + 70
Storage Temperature	°C	- 40 to + 85
Package Dimensions	mm	12 × 17 × 39

*IL is 0.3 dB higher, RL is 5 dB lower, and ER is 2 dB lower for each connector added. Connector key is aligned to slow axis.

**The Optical Power is 1W only for connector added.

Package Dimensions

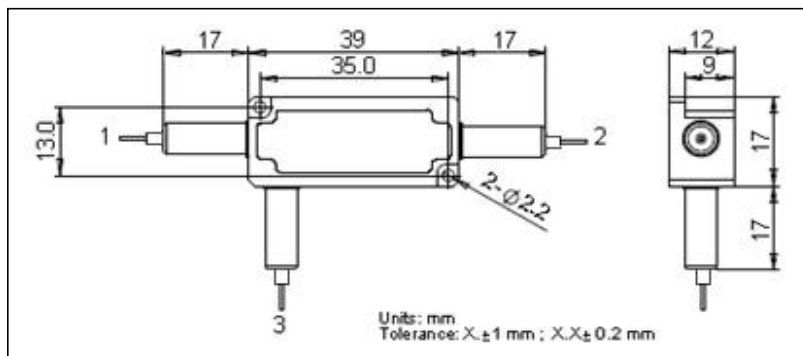

Ordering Information

PMCIR-①①①①-②-③-④-⑤-⑥-⑦-⑧

①①①①: Wavelength

②: Handling Power

③: Connector Type

④: Fiber Jacket

2000 - 2000 nm

03 - 0.3 W 05 - 0.5 W

1 - FC/UPC 3 - SC/UPC

B - 250 μm Panda fiber

SSSS - Specify

1 - 1 W 5 - 5 W

2 - FC/APC 4 - SC/APC

L - 900 μm loose tube

2 - 2 W S - Specify

N - None S - Specify

S - Specify

⑤: Fiber Length

⑥: Working Axis

⑦: Fiber Type

⑧: Power Type

Q - 0.75 m

F - Fast axis blocked

1 - PM1550 fiber

P - Pulse Application

S - Specify

B - Both axis working

2 - Nufern PM1950 fiber

C - Continuous Wave

3 - Thorlabs PM2000 fiber